

Advanced  
Engineering

Hitachi Tool

**HITACHI**  
Inspire the Next

**MINIATURE**

No. 404.2

# Miniature

## Micro Grain Carbide End Mills

Ø 0.2 mm ~ Ø 6.0 mm (HSC-HPC-HHC)

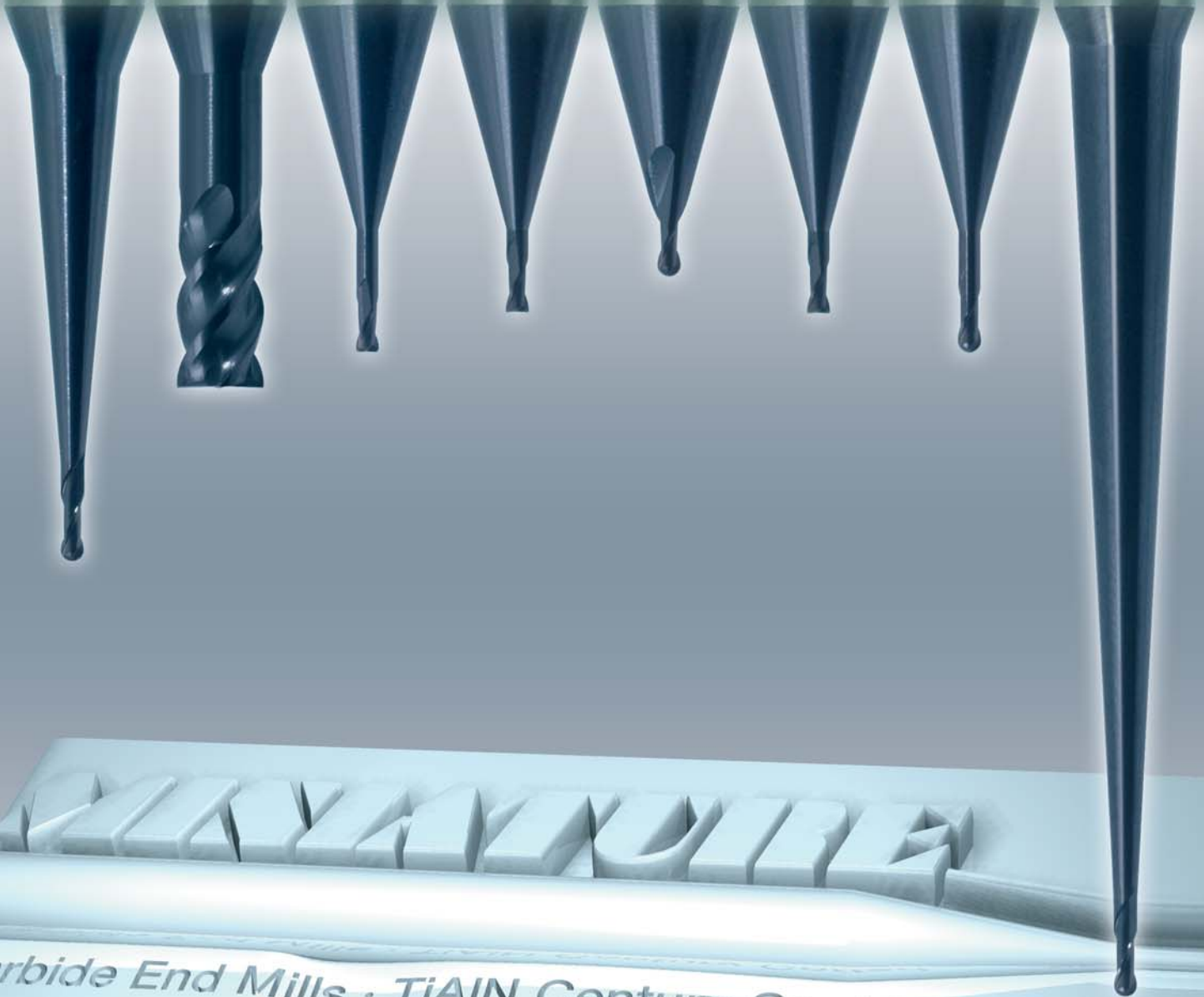



## Ball Type



Hyper Ball Short  
**HPBS**

1 – 6 mm

4



Hyper Ball  
**HYPB**

0.2 – 6 mm

5



Hyper Ball Long Neck  
**HPBLN**

0.5 – 6 mm

6



Epoch Ball Pencil Neck  
**EPBPN**

1°30' / 3° / 5°

1 – 6 mm

7



Carbide Ball Taper Neck  
**BESL-C**

1°

3 – 6 mm

8



Carbide Ball Long Neck  
**BESL-SC**

3 – 6 mm

9



## Square Type

### Epoch21

Hyper Square <b>HYPS</b>	0.2 – 6 mm		<b>10</b>
Hyper Square Corner Radius <b>HYPS-00</b>	0.5 – 3 mm		<b>11</b>
Hyper Square Long Neck <b>HPSLN</b>	0.5 – 6 mm		<b>12</b>
Hyper Square Long Neck Corner Radius <b>HPSLN-00</b>	0.5 – 4 mm		<b>13</b>
Epoch Power Mill Long Shank <b>EPPLS</b>	3 – 5 mm		<b>14</b>
Epoch Power Mill Long Shank Corner Radius <b>EPPLS-00</b>	3 – 5 mm		<b>15</b>



## Ball Type

### HPBS | Hyper Ball Short

<b>V max</b> High Speed	 Semi-Finishing	 Finishing	<b>HRC</b> 65	 Rib. Miniature	<b>No. of Teeth</b> 2
----------------------------	--------------------	---------------	------------------	--------------------	--------------------------

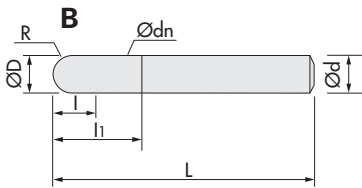

R	± 0.005
D	0/-0.015
d	0/-0.005

<b>Carbide</b> Micro grain	<b>C</b> Century Coating	<b>Rake Angle</b> Positive
-------------------------------	-----------------------------	-------------------------------

ID Code	Item No.	Stock	Z	R	ØD	θ°	l	dn	l <sub>1</sub>	l <sub>n1</sub>	l <sub>n2</sub>	l <sub>s</sub>	L	d	Type
CC 132	<b>HPBS-2010C</b>	■	2	0.5	<b>1</b>		1.3	0.95	2				50	6	A
CC 133	<b>HPBS-2020C</b>	■	2	1	<b>2</b>		2.5	1.95	3.5				50	6	A
CC 134	<b>HPBS-2030C</b>	■	2	1.5	<b>3</b>		4	2.9	5				50	6	A
CC 135	<b>HPBS-2040C</b>	■	2	2	<b>4</b>		5	3.9	6				50	6	A
CC 136	<b>HPBS-2050C</b>	■	2	2.5	<b>5</b>		6	4.9	7				50	6	A
CC 137	<b>HPBS-2060C</b>	■	2	3	<b>6</b>		7.5	5.9	9				50	6	B

■ = Stock | Germany



## Ball Type

### HYPB | Hyper Ball

<b>V max</b> High Speed	Semi-Finishing	Finishing	<b>HRC</b> 65	Rib. Miniature	<b>No. of Teeth</b> 2
----------------------------	----------------	-----------	------------------	----------------	--------------------------

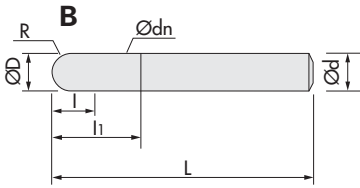
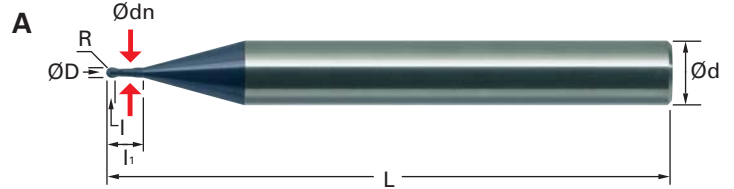

R	± 0.005
D	0/-0.015
d	0/-0.005

<b>Carbide</b> Micro Grain	<b>C</b> Century Coating	<b>Rake Angle</b> Positive
-------------------------------	-----------------------------	-------------------------------

ID Code	Item No.	Stock	Z	R	ØD	θ°	l	dn	l <sub>1</sub>	l <sub>n1</sub>	l <sub>n2</sub>	l <sub>s</sub>	L	d	Type
CC 086	<b>HYPB-2002C</b>	■	2	0.1	<b>0.2</b>		0.3						50	6	A
CC 087	<b>HYPB-2003C</b>	■	2	0.15	<b>0.3</b>		0.4						50	6	A
CC 026	<b>HYPB-2004C</b>	■	2	0.2	<b>0.4</b>		0.5						50	6	A
CC 088	<b>HYPB-2005C</b>	■	2	0.25	<b>0.5</b>		0.6	0.45	1.6				50	6	A
CC 027	<b>HYPB-2006C</b>	■	2	0.3	<b>0.6</b>		0.7	0.55	1.7				50	6	A
CC 089	<b>HYPB-2008C</b>	■	2	0.4	<b>0.8</b>		1	0.75	2.5				50	6	A
CC 028	<b>HYPB-2010C</b>	■	2	0.5	<b>1</b>		1.3	0.95	3.3				50	6	A
CC 090	<b>HYPB-2012C</b>	■	2	0.6	<b>1.2</b>		1.5	1.15	3.5				50	6	A
CC 091	<b>HYPB-2014C</b>	■	2	0.7	<b>1.4</b>		1.8	1.35	3.8				50	6	A
CC 029	<b>HYPB-2015C</b>	■	2	0.75	<b>1.5</b>		1.9	1.45	4.9				50	6	A
CC 092	<b>HYPB-2016C</b>	■	2	0.8	<b>1.6</b>		2	1.55	5				50	6	A
CC 093	<b>HYPB-2018C</b>	■	2	0.9	<b>1.8</b>		2.3	1.75	5.3				50	6	A
CC 030	<b>HYPB-2020C</b>	■	2	1	<b>2</b>		2.5	1.95	5.5				50	6	A
CC 094	<b>HYPB-2025C</b>	■	2	1.25	<b>2.5</b>		3	2.4	6				50	6	A
CC 031	<b>HYPB-2030C</b>	■	2	1.5	<b>3</b>		4	2.9	8				50	6	A
CC 095	<b>HYPB-2035C</b>	■	2	1.75	<b>3.5</b>		4.5	3.4	8.5				50	6	A
CC 032	<b>HYPB-2040C</b>	■	2	2	<b>4</b>		5	3.9	10				50	6	A
CC 033	<b>HYPB-2050C</b>	■	2	2.5	<b>5</b>		6	4.9	11				50	6	A
CC 034	<b>HYPB-2060C</b>	■	2	3	<b>6</b>		7.5	5.9	12.5				50	6	B

■ = Stock | Germany



## Ball Type

### HPBLN | Hyper Ball Long Neck

<b>V max</b> High Speed	<b>▽▽</b> Semi-Finishing	<b>▽▽▽</b> Finishing	<b>HRC</b> 65	<b>Rib. Miniature</b>	<b>No. of Teeth</b> 2
----------------------------	-----------------------------	-------------------------	------------------	-----------------------	--------------------------

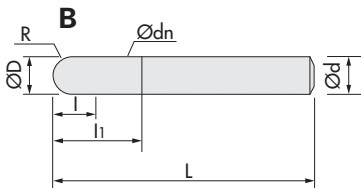

R	± 0.005
D	0/-0.015
d	0/-0.005

<b>Carbide</b> Micro Grain	<b>C</b> Century Coating	<b>Rake Angle</b> Positive
-------------------------------	-----------------------------	-------------------------------

ID Code	Item No.	Stock	Z	R	ØD	θ°	l	dn	l <sub>1</sub>	l <sub>n1</sub>	l <sub>n2</sub>	l <sub>s</sub>	L	d	Type
CC 138	HPBLN-2005C	■	2	0.25	0.5		0.6	0.45	2.5				60	6	A
CC 139	HPBLN-2006C	■	2	0.3	0.6		0.7	0.55	3				60	6	A
CC 140	HPBLN-2008C	■	2	0.4	0.8		1	0.75	4				60	6	A
CC 141	HPBLN-2010C	■	2	0.5	1		1.3	0.95	5				60	6	A
CC 142	HPBLN-2012C	■	2	0.6	1.2		1.5	1.15	6				60	6	A
CC 143	HPBLN-2014C	■	2	0.7	1.4		1.8	1.35	7				60	6	A
CC 144	HPBLN-2015C	■	2	0.75	1.5		1.9	1.45	7.5				60	6	A
CC 145	HPBLN-2016C	■	2	0.8	1.6		2	1.55	8				60	6	A
CC 146	HPBLN-2018C	■	2	0.9	1.8		2.3	1.75	9				60	6	A
CC 147	HPBLN-2020C	■	2	1	2		2.5	1.95	10				60	6	A
CC 148	HPBLN-2025C	■	2	1.25	2.5		3	2.4	12.5				60	6	A
CC 149	HPBLN-2030C	■	2	1.5	3		4	2.9	15				80	6	A
CC 150	HPBLN-2035C	■	2	1.75	3.5		4.5	3.4	17.5				80	6	A
CC 151	HPBLN-2040C	■	2	2	4		5	3.9	20				80	6	A
CC 152	HPBLN-2050C	■	2	2.5	5		6	4.9	25				80	6	A
CC 153	HPBLN-2060C	■	2	3	6		7.5	5.9	30				80	6	B

■ = Stock | Germany

Carbide End Mills - TiAlN Century

## Ball Type

### EPBPN | Epoch Ball Pencil Neck

<b>V max</b> High Speed	 Finishing	<b>HRC</b> 65	 Rib. Miniature	<b>No. of Teeth</b> 2
----------------------------	---------------	------------------	--------------------	--------------------------

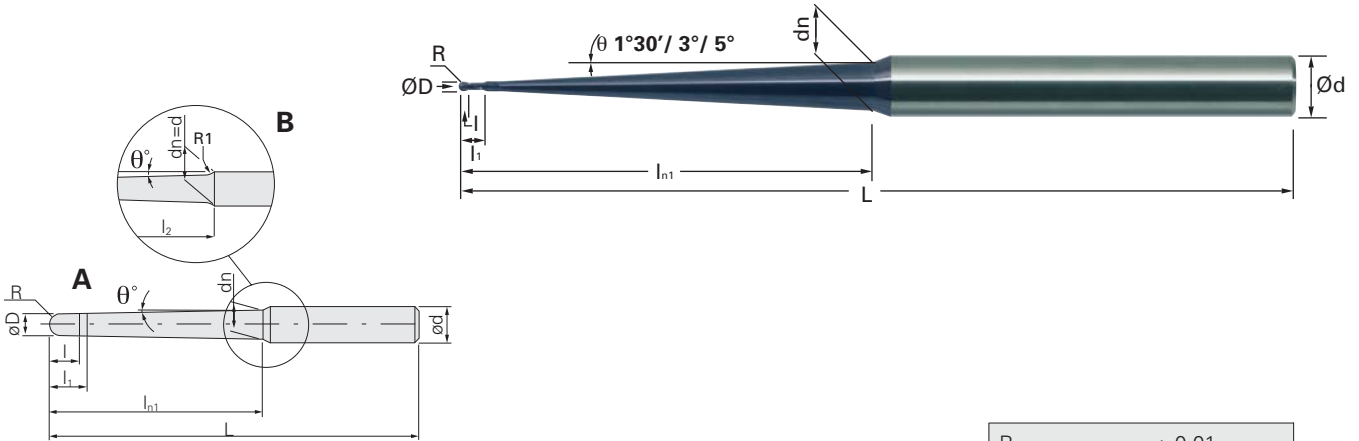
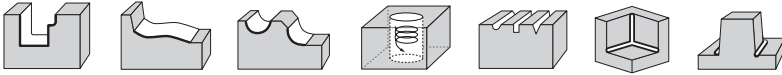

R	± 0.01
D	0/-0.01
d	h6

<b>Carbide</b> Micro grain	<b>C</b> Century Coating	<b>Rake Angle</b> Positive
-------------------------------	-----------------------------	-------------------------------

ID Code	Item No.	Stock	Z	R	ØD	θ°	I	dn	I <sub>1</sub>	I <sub>n1</sub>	I <sub>n2</sub>	I <sub>s</sub>	L	d	Type
EP 186	<b>EPBPN-2010-15</b>	■	2	0.5	<b>1</b>	1°30'	2.5	1.8	4	20			60	6	A
EP 187	<b>EPBPN-2010-30</b>	■	2	0.5	<b>1</b>	3°	2.5	4.8	4	40			80	6	A
EP 188	<b>EPBPN-2010-50</b>	■	2	0.5	<b>1</b>	5°	2.5	3.8	4	20			60	6	A
EP 189	<b>EPBPN-2020-15</b>	■	2	1	<b>2</b>	1°30'	5	2.7	7	20			60	6	A
EP 190	<b>EPBPN-2020-30</b>	■	2	1	<b>2</b>	3°	5	5.5	7	40			80	6	A
EP 191	<b>EPBPN-2020-50</b>	■	2	1	<b>2</b>	5°	5	4.3	7	20			60	6	A
EP 192	<b>EPBPN-2030-15</b>	■	2	1.5	<b>3</b>	1°30'	8	5.1	10	50			90	6	A
EP 193	<b>EPBPN-2030-30</b>	■	2	1.5	<b>3</b>	3°	8	5.1	10	30			70	6	A
EP 194	<b>EPBPN-2040-15</b>	■	2	2	<b>4</b>	1°30'	8	6	10	48.2			90	6	B
EP 195	<b>EPBPN-2040-30</b>	■	2	2	<b>4</b>	3°	8	6	10	29.1			70	6	B
EP 196	<b>EPBPN-2050-15</b>	■	2	2.5	<b>5</b>	1°30'	10	7.5	12	60			110	8	A
EP 197	<b>EPBPN-2050-30</b>	■	2	2.5	<b>5</b>	3°	10	8	12	40.6			90	8	B
EP 198	<b>EPBPN-2060-15</b>	■	2	3	<b>6</b>	1°30'	12	8	14	52.2			110	8	B
EP 199	<b>EPBPN-2060-30</b>	■	2	3	<b>6</b>	3°	12	8	14	33.1			90	8	B

■ = Stock | Germany



## Ball Type

### BESL-C | Carbide Ball Taper Neck

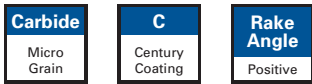
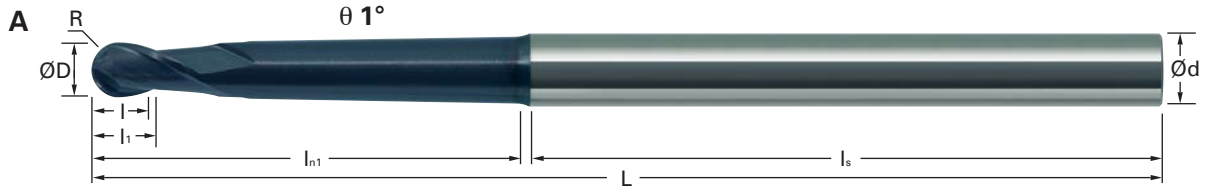
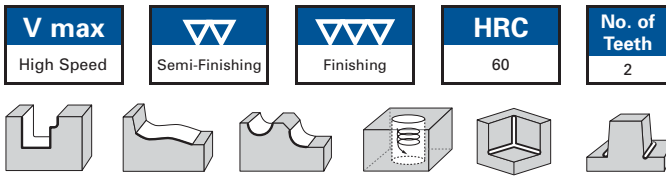

R	± 0.02
D	0/-0.02
d	h6

ID Code	Item No.	Stock	Z	R	ØD	θ°	I	dn	I <sub>1</sub>	I <sub>n1</sub>	I <sub>n2</sub>	I <sub>s</sub>	L	d	Type
CC 043	<b>BESL-2030C</b>	■	2	1.5	<b>3</b>	1°	4		5	35		62.3	100	6	A
CC 044	<b>BESL-2040C</b>	■	2	2	<b>4</b>	1°	6		7	35		63.6	100	6	A
CC 041	<b>BESL-2050C</b>	■	2	2.5	<b>5</b>	1°	7		8	40		72.4	115	8	A
CC 042	<b>BESL-2060C</b>	■	2	3	<b>6</b>	1°	8		9	45		68.7	115	8	A

■ = Stock | Germany



## Ball Type

### BESL-SC | Carbide Ball Long Neck

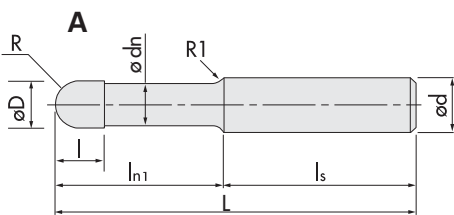
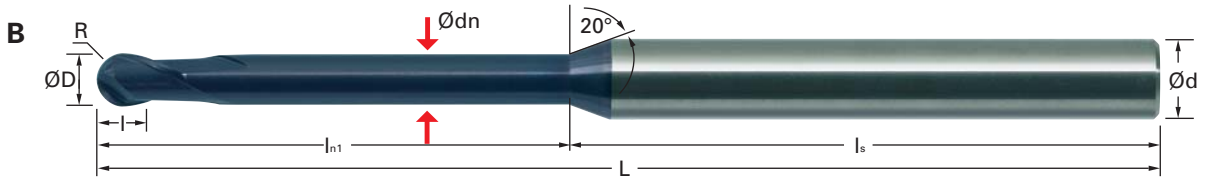
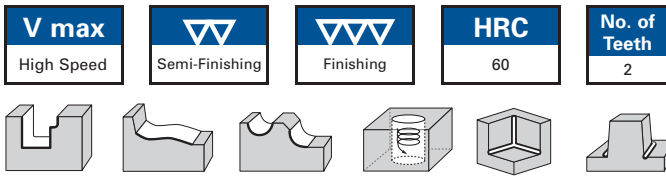

R	± 0.02
D	0/-0.02
d	h6

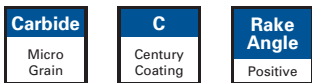

ID Code	Item No.	Stock	Z	R	ØD	θ°	l	dn	l <sub>1</sub>	l <sub>n1</sub>	l <sub>n2</sub>	l <sub>s</sub>	L	d	Type
CC 053	<b>BESL-2030SC</b>	■	2	1.5	<b>3</b>	4	2.8			35		65	100	6	B
CC 054	<b>BESL-2040SC</b>	■	2	2	<b>4</b>	6	3.8			35		65	100	6	B
CC 055	<b>BESL-2050SC</b>	■	2	2.5	<b>5</b>	7	4.8			40		75	115	6	B
CC 056	<b>BESL-2060SC</b>	■	2	3	<b>6</b>	8	5.8			45		70	115	6	A

■ = Stock | Germany





## Square Type

### HYPS | Hyper Square

<b>V max</b> High Speed	 Finishing	<b>HRC</b> 65	 Rib. Miniature	<b>No. of Teeth</b> 2
----------------------------	---------------	------------------	--------------------	--------------------------

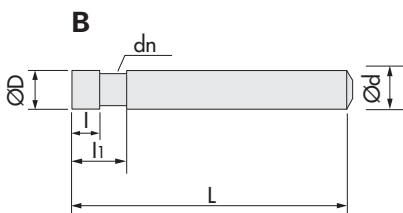
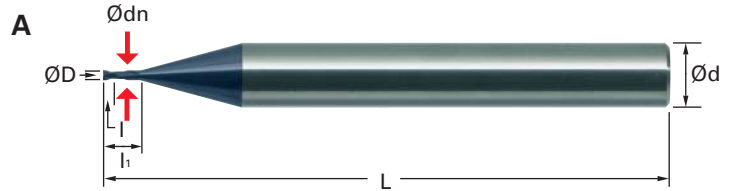
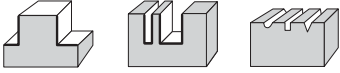

<b>Carbide</b> Micro Grain	<b>C</b> Century Coating	<b>Rake Angle</b> Positive
-------------------------------	-----------------------------	-------------------------------

D	0/-0.015
d	0/-0.005

ID Code	Item No.	Stock	Z	R	ØD	θ°	l	dn	l <sub>1</sub>	l <sub>n1</sub>	l <sub>n2</sub>	l <sub>s</sub>	L	d	Type
CC 096	HYPS-2002C	■	2		0.2		0.3						50	6	A
CC 035	HYPS-2003C	■	2		0.3		0.4						50	6	A
CC 097	HYPS-2004C	■	2		0.4		0.5						50	6	A
CC 036	HYPS-2005C	■	2		0.5		0.6	0.45	1.6				50	6	A
CC 037	HYPS-2006C	■	2		0.6		0.7	0.55	1.7				50	6	A
CC 098	HYPS-2008C	■	2		0.8		1	0.75	2.5				50	6	A
CC 038	HYPS-2010C	■	2		1		1.3	0.95	3.3				50	6	A
CC 099	HYPS-2012C	■	2		1.2		1.5	1.15	3.5				50	6	A
CC 100	HYPS-2014C	■	2		1.4		1.8	1.35	3.8				50	6	A
CC 039	HYPS-2015C	■	2		1.5		1.9	1.45	4.9				50	6	A
CC 101	HYPS-2016C	■	2		1.6		2	1.55	5				50	6	A
CC 102	HYPS-2018C	■	2		1.8		2.3	1.75	5.3				50	6	A
CC 040	HYPS-2020C	■	2		2		2.5	1.95	5.5				50	6	A
CC 103	HYPS-2025C	■	2		2.5		3	2.4	6				50	6	A
CC 104	HYPS-2030C	■	2		3		4	2.9	8				50	6	A
CC 105	HYPS-2035C	■	2		3.5		4.5	3.4	8.5				50	6	A
CC 106	HYPS-2040C	■	2		4		5	3.9	10				50	6	A
CC 107	HYPS-2050C	■	2		5		6	4.9	11				50	6	A
CC 108	HYPS-2060C	■	2		6		7.5	5.9	12.5				50	6	B

■ = Stock | Germany

## Square Type

### HYPS-00 | Hyper Square Corner Radius

<b>V max</b> High Speed	 Finishing	<b>HRC</b> 65	 Rib. Miniature	<b>No. of Teeth</b> 2
----------------------------	---------------	------------------	--------------------	--------------------------

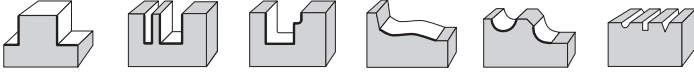

<b>Carbide</b> Micro Grain	<b>C</b> Century Coating	<b>Rake Angle</b> Positive
-------------------------------	-----------------------------	-------------------------------

R	± 0.01
D	0/-0.015
d	0/-0.005

ID Code	Item No.	Stock	Z	R	ØD	θ°	l	dn	l <sub>1</sub>	l <sub>n1</sub>	l <sub>n2</sub>	l <sub>s</sub>	L	d	Type
CC 188	HYPS-2005-01C	■	2	0.1	0.5	0.6	0.45	1.6					50	6	A
CC 189	HYPS-2010-02C	■	2	0.2	1	1.3	0.95	3.3					50	6	A
CC 190	HYPS-2015-02C	■	2	0.2	1.5	1.9	1.45	4.9					50	6	A
CC 191	HYPS-2020-02C	■	2	0.2	2	2.5	1.95	5.5					50	6	A
CC 192	HYPS-2020-05C	■	2	0.5	2	2.5	1.95	5.5					50	6	A
CC 193	HYPS-2025-02C	■	2	0.2	2.5	3	2.4	6					50	6	A
CC 194	HYPS-2025-05C	■	2	0.5	2.5	3	2.4	6					50	6	A
CC 195	HYPS-2030-02C	■	2	0.2	3	4	2.9	8					50	6	A
CC 196	HYPS-2030-05C	■	2	0.5	3	4	2.9	8					50	6	A

■ = Stock | Germany





## Square Type

### HPSLN | Hyper Square Long Neck

<b>V max</b> High Speed	<b>▽▽▽</b> Finishing	<b>HRC</b> 65	<b>Rib. Miniature</b>	<b>No. of Teeth</b> 2
----------------------------	-------------------------	------------------	-----------------------	--------------------------

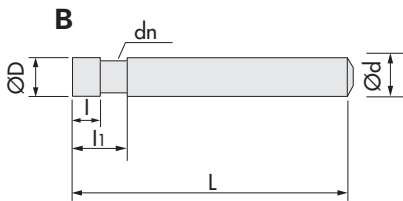
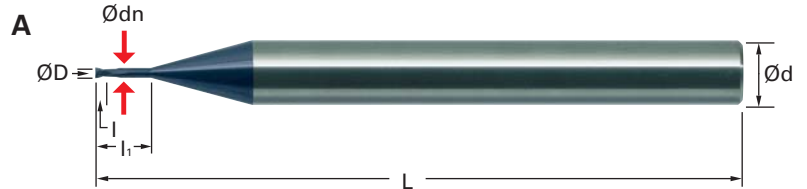
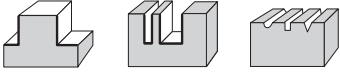

<b>Carbide</b> Micro Grain	<b>C</b> Century Coating	<b>Rake Angle</b> Positive
-------------------------------	-----------------------------	-------------------------------

D	0/-0.015
d	0/-0.005

ID Code	Item No.	Stock	Z	R	ØD	θ°	l	dn	l <sub>1</sub>	l <sub>n1</sub>	l <sub>n2</sub>	l <sub>s</sub>	L	d	Type
CC 154	HPSLN-2005C	■	2		0.5	0.6	0.45	2.5					60	6	A
CC 155	HPSLN-2006C	■	2		0.6	0.7	0.55	3					60	6	A
CC 156	HPSLN-2008C	■	2		0.8	1	0.75	4					60	6	A
CC 157	HPSLN-2010C	■	2		1	1.3	0.95	5					60	6	A
CC 158	HPSLN-2012C	■	2		1.2	1.5	1.15	6					60	6	A
CC 159	HPSLN-2014C	■	2		1.4	1.8	1.35	7					60	6	A
CC 160	HPSLN-2015C	■	2		1.5	1.9	1.45	7.5					60	6	A
CC 161	HPSLN-2016C	■	2		1.6	2	1.55	8					60	6	A
CC 162	HPSLN-2018C	■	2		1.8	2.3	1.75	9					60	6	A
CC 163	HPSLN-2020C	■	2		2	2.5	1.95	10					60	6	A
CC 164	HPSLN-2025C	■	2		2.5	3	2.4	12.5					60	6	A
CC 165	HPSLN-2030C	■	2		3	4	2.9	15					80	6	A
CC 166	HPSLN-2035C	■	2		3.5	4.5	3.4	17.5					80	6	A
CC 167	HPSLN-2040C	■	2		4	5	3.9	20					80	6	A
CC 168	HPSLN-2050C	■	2		5	6	4.9	25					80	6	A
CC 169	HPSLN-2060C	■	2		6	7.5	5.9	30					80	6	B

■ = Stock | Germany

Carbide End Mills - TiAlN Century

## Square Type

### HPSLN-00 | Hyper Square Long Neck Corner Radius

<b>V max</b> High Speed	 Finishing	<b>HRC</b> 65	 Rib. Miniature	<b>No. of Teeth</b> 2
----------------------------	---------------	------------------	--------------------	--------------------------



<b>Carbide</b> Micro Grain	<b>C</b> Century Coating	<b>Rake Angle</b> Positive
-------------------------------	-----------------------------	-------------------------------

R	± 0.01
D	0/-0.015
d	0/-0.005

ID Code	Item No.	Stock	Z	R	ØD	θ°	l	dn	l <sub>1</sub>	l <sub>n1</sub>	l <sub>n2</sub>	l <sub>s</sub>	L	d	Type
CC 172	HPSLN-2005-01C	■	2	0.1	0.5	0.6	0.45	2.5					60	6	A
CC 173	HPSLN-2010-02C	■	2	0.2	1	1.3	0.95	5					60	6	A
CC 174	HPSLN-2015-02C	■	2	0.2	1.5	1.9	1.45	7.5					60	6	A
CC 175	HPSLN-2020-02C	■	2	0.2	2	2.5	1.95	10					60	6	A
CC 176	HPSLN-2020-05C	■	2	0.5	2	2.5	1.95	10					60	6	A
CC 177	HPSLN-2025-02C	■	2	0.2	2.5	3	2.4	12.5					60	6	A
CC 178	HPSLN-2025-05C	■	2	0.5	2.5	3	2.4	12.5					60	6	A
CC 179	HPSLN-2030-02C	■	2	0.2	3	4	2.9	15					80	6	A
CC 180	HPSLN-2030-05C	■	2	0.5	3	4	2.9	15					80	6	A

■ = Stock | Germany





## Square Type

### EPPLS | Epoch Power Mill Long Shank

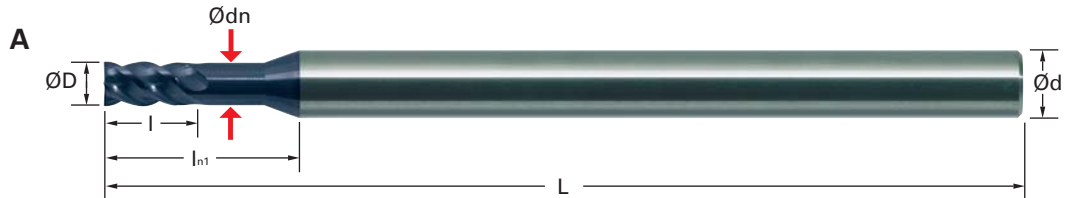
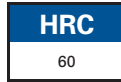

DØ3.0	-0.014/-0.028
DØ4.0~Ø5.0	-0.020/-0.038
d	h6

ID Code	Item No.	Stock	Z	R	ØD	θ°	l	dn	l <sub>1</sub>	l <sub>n1</sub>	l <sub>n2</sub>	l <sub>s</sub>	L	d	Type
EP 156	<b>EPPLS-4030</b>	■	4	3	3	4.5	2.9			10.5			80	6	A
EP 157	<b>EPPLS-4040</b>	■	4	4	4	6	3.8			14			80	6	A
EP 158	<b>EPPLS-4050</b>	■	4	5	5	7.5	4.8			17.5			100	6	A

■ = Stock | Germany



## Square Type

### EPPLS-00 | Epoch Power Mill Long Shank Corner Radius

Semi-Finishing	Finishing	<b>HRC</b> 60	<b>No. of Teeth</b> 4
----------------	-----------	------------------	--------------------------

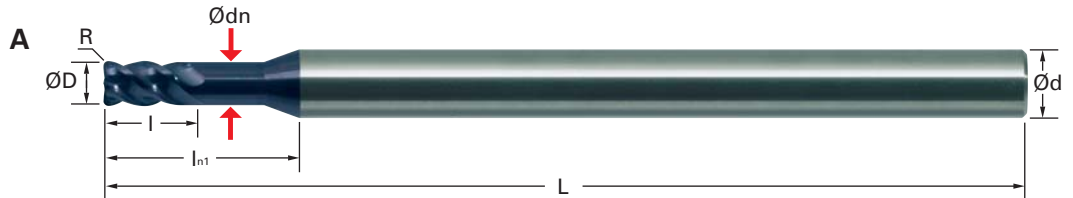

<b>Carbide</b> Micro Grain	<b>C</b> Century Coating	<b>Rake Angle</b> Positive
-------------------------------	-----------------------------	-------------------------------



R	± 0.015
DØ3.0	-0.014/-0.028
DØ4.0~Ø5.0	-0.020/-0.038
d	h6

ID Code	Item No.	Stock	Z	R	ØD	θ°	l	dn	l <sub>1</sub>	l <sub>n1</sub>	l <sub>n2</sub>	l <sub>s</sub>	L	d	Type
EP 164	<b>EPPLS-4030-02</b>	■	4	0.2	<b>3</b>		4.5	2.9		10.5			80	6	A
EP 165	<b>EPPLS-4030-05</b>	■	4	0.5	<b>3</b>		4.5	2.9		10.5			80	6	A
EP 166	<b>EPPLS-4040-02</b>	■	4	0.2	<b>4</b>		6	3.8		14			80	6	A
EP 167	<b>EPPLS-4040-05</b>	■	4	0.5	<b>4</b>		6	3.8		14			80	6	A
EP 168	<b>EPPLS-4050-02</b>	■	4	0.2	<b>5</b>		7.5	4.8		17.5			100	6	A
EP 169	<b>EPPLS-4050-05</b>	■	4	0.5	<b>5</b>		7.5	4.8		17.5			100	6	A

■ = Stock | Germany



**Product Range**

Solid Carbide End Mills

microEndMill

Epoch21

MINIATURE

3D-Cut

CARBIDE

Indexable Milling Tools

Indexable  
MillingESM Speed End Mills  
EMC Power DrillsESM  
SPEED

Milling Chucks

Milling  
Chucks

Distributed by:

**Hitachi Tool Engineering Europe GmbH**

Itterpark 12 · 40724 Hilden · Germany · Phone +49 (0) 21 03 – 24 82-0 · Fax +49 (0) 21 03 – 24 82-30

e-Mail [info@hitachitool-eu.com](mailto:info@hitachitool-eu.com) · Internet [www.hitachitool-eu.com](http://www.hitachitool-eu.com)

© 2007 by Hitachi Tool Engineering Europe GmbH · 2nd Edition · Printed in Germany